

DOUG THORLEY HEADERS

BY SUMMIT INDUSTRIES

THY-372Y / THY-372Y-S

CHEVROLET 283-400
67-72 PICKUP

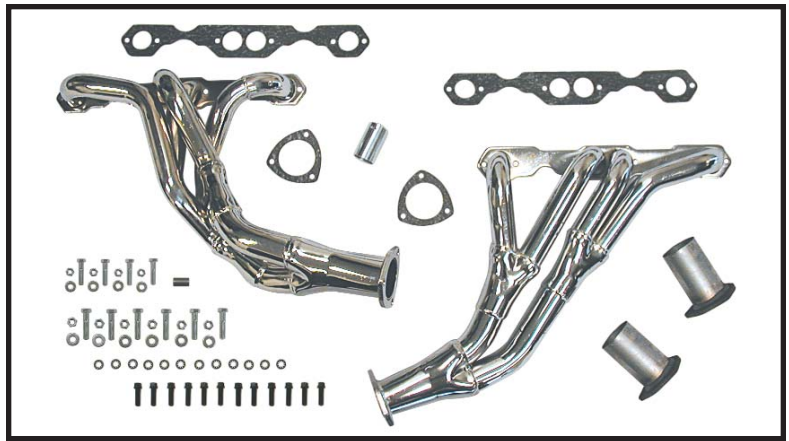

PARTS INCLUDED

- 1 - Right side header
- 1 - Left side header
- 1 - Hot air pickup
- 2 - Reducers
- 2 - Collector gaskets
- 2 - Header gaskets

HARDWARE INCLUDED

- 12 - 3/8"-16 x 1" Header bolts
- 12 - 3/8" Star lock washers
- 6 - 3/8"-16 x 1-1/4" Hex head bolts
- 6 - 3/8"-16 Hex nuts
- 6 - 3/8" Flat washers
- 4 - 1/4"-20 x 1-1/4" Hex head bolts
- 4 - 1/4"-20 Hex nuts
- 4 - 1/4" Flat washers
- 4 - 1/4" Star lock washers
- 1 - 5/8" x 1" Spacer

TOOLS REQUIRED

- Heating torch
- Mig welder
- Cut-off saw
- Sawzall
- 3/8", 7/16", 9/16", 1/2", 3/4", 7/8" Wrenches
- 10mm, 13mm Wrenches
- 9/16" Line (flare nut) wrench
- 5/16", 7/16", 1/2", 9/16" Sockets
- 3/8", 7/16" Deep sockets
- 15mm Deep socket
- 5/8" Spark plug socket
- Ratchet and extensions
- Pliers
- Crescent wrench
- Torque wrench
- Rust penetrant
- High-temp sensor-safe silicon sealer (rated at 600 degrees+)

WARRANTY NOTES

- 1) The utmost care is taken at Thorley Headers to maintain the highest standards of quality. However, Thorley Headers cannot control the installation of the product. For this reason, the Thorley Headers warranty covers only the replacement of the components - not the labor for the installation.
- 2) The use of any type of "header wrapping" voids the warranty. Using any sort of wrapping material on the headers destroys the tubing's ability to dissipate heat, causing very rapid deterioration of the metal and the subsequent failure of the headers.
- 3) The chrome plating applied to all Thorley headers is a high-nickel chrome finish applied to retard corrosion. This is a "heat" chrome to preserve the metal. This finish is not "show chrome" intended for the sake of appearance. This high-nickel chrome turns colors and approaches black as it cooks into the metal. The brilliance of the chrome finish is not covered under the warranty. Contamination of the surface by foreign substances may produce other color patterns. This can be prevented by routine cleaning.

THY-372Y / THY-372Y-S

CHEVROLET 283-400
67-72 PICKUP

WARRANTY NOTES

- 4) Retain all paperwork pertaining to the purchase of your Thorley product. Save your receipt!
Your limited warranty is not valid without a receipt of purchase.

LEGALITY NOTE

The installation of headers onto any vehicle must be performed in accordance with all governmental regulations that might pertain to the particular vehicle receiving the headers. Please call your Thorley Headers distributor if there are any questions regarding the legality of the installation. This part number is considered a legal replacement part on vehicles that do not have a catalytic converter, as long as all original emission control devices are connected and functioning properly. As a result, **this part number does not require an Executive Order (“E.O.”) number.**

INSTALLATION NOTES

- 1) It is important that you read the entire instruction sheet before initiating any installation.
- 2) Thorley headers are designed to fit only factory installed engine and transmission combinations. We cannot guarantee that Thorley headers will fit in the case of “engine swaps” or “transmission swaps”.
- 3) Due to restricted room in the engine compartment, your headers may come close to certain body and chassis components. This is normal for an installation of this type. However, a careful inspection must be completed to insure that the distances and placement are reasonable and logical, especially with regard to electrical, fuel, and brake components.
- 4) Because of the requirement to raise the engine to facilitate header installation, the engine mounts should be carefully inspected at that point of the installation. It is highly recommended that questionable or deteriorated engine mounts be replaced during the installation of the headers. In some cases, the engine mounts need to be loosened and repositioned to provide optimum header clearance from some components.
- 5) Because of car-to-car variations, Thorley Headers strongly recommends that these headers be installed by a competent exhaust shop that has welding and fabrication capabilities.

THY-372Y / THY-372Y-S

CHEVROLET 283-400
67-72 PICKUP

INSTALLATION PROCEDURES

WARNING! - Do not rely on bumper jacks or chassis jacks for support during header installation. The subject vehicle should be raised and supported with jacking equipment and jackstands or ramps intended for undercarriage auto maintenance. It is extremely dangerous to work under an improperly raised and/or supported vehicle.

WARNING! - Make certain there is ample clearance around components such as brake lines, brake proportioning valves, fuel lines, hoses and pumps, and electrical components and wires. In some cases it may be necessary to relocate items that may be adversely affected by exhaust system heat.

NOTE: These procedures are documented on factory standard-equipped vehicles with original configuration compliance. Any modification of the subject vehicle may dictate modification to these procedures.

NOTE: All Thorley headers featuring air injection options are designed to accept the most readily available original equipment manufacturer's looms. Should your stock looms not match the fittings on the headers, or should you suspect that your original looms will not survive the re-installation onto the Thorley headers, your local GM parts department may be able to provide replacements using these part numbers:

THY-372Y-S driver and passenger side - 330544.

- 1) Disconnect the battery.
- 2) Raise the front of the vehicle approximately 24 inches and support it with jack stands or other suitable supports. (**WARNING!** - Do not rely on bumper jacks or chassis jacks for support during header installation. The subject vehicle should be raised and supported with jacking equipment and jackstands or ramps intended for undercarriage auto maintenance. It is extremely dangerous to work under an improperly raised and/or supported vehicle.)
- 3) Remove the air cleaner and the engine oil dipstick.
- 4) Note the location of the spark plug wires and remove them from the spark plugs.
- 5) If applicable, remove the spark plug wire looms from the exhaust side of the cylinder heads (leaving the wires in the looms), and secure them out of the way.

THY-372Y / THY-372Y-S

**CHEVROLET 283-400
67-72 PICKUP**

- 6) Remove the spark plugs.
- 7) If applicable, remove the A.I.R. harnesses (smog pump fittings) from the stock exhaust manifolds and disconnect them at the junction to the hoses.
- 8) Remove the stock head pipes.
- 9) If the vehicle is equipped with a two-piece oil dipstick tube, remove the bolt that attaches the bottom half of the tube to the engine block. Remove the top half bracket, and remove both halves from the vehicle.
- 10) If the vehicle is equipped with a one-piece oil dipstick tube, carefully thread a ¼" bolt (of at least 1" in length) into the top of the tube to prevent it from being crushed during removal. Then twist the tube with a pair of pliers (affixed to the part of the tube with the bolt in it) to remove it.
- 11) Remove the stock exhaust manifolds.
- 12) Clean all traces of carbon deposits from the cylinder head exhaust port surfaces.
- 13) If applicable, trial fit the A.I.R. harnesses to the headers before installing the headers. Make any necessary modifications or adjustments, then remove the harnesses before installing the headers.
- 14) (Note: The use of high-temp sensor-safe silicon sealer between the header flange and header gasket is highly recommended.) Install the headers and supplied header gaskets from below the vehicle using the supplied 3/8"-16 x 1" header bolts and star lock washers. Vehicles that are equipped with bracketry that attaches to the driver side front bolt must use the original stock bolt (not a supplied header bolt) in that location, along with the supplied spacer. Do not fully tighten at this time. (Note: Some models may require various modifications as shown in Illustrations, Figures 1-8.)
- 15) If applicable, attach the A.I.R. harnesses to the fittings on the headers. Do not fully tighten at this time.
- 16) Tighten all header bolts to 35 ft/lbs.
- 17) Reinstall the engine oil dipstick tube.

THY-372Y / THY-372Y-S

**CHEVROLET 283-400
67-72 PICKUP**

- 18) If applicable, securely tighten all A.I.R. harness nuts.
- 19) Reinstall the spark plugs and reconnect the wires.
- 20) Attach the supplied reducers to the header collectors using the supplied collector gaskets, 3/8"-16 x 1-1/4" hex head bolts, nuts, and washers.
- 21) Cut the stock head pipes appropriately and weld or clamp them to the reducers.
- 22) Reinstall the air cleaner assembly and the engine oil dipstick.
- 23) Reconnect the battery. Start the engine and check for leaks.
- 24) Because the header bolts will initially stretch when hot, we recommend adhering to the following steps:
 - a) Retighten the header bolts to 35 ft/lbs after approximately twenty minutes of operation.
(Note: Remember the engine will be hot at this time. Protect yourself accordingly.)
 - b) Check and retighten the header bolts to 35 ft/lbs after the first month of operation.

THY-372Y / THY-372Y-S

**CHEVROLET 283-400
67-72 PICKUP**

ILLUSTRATIONS

FIGURE 1

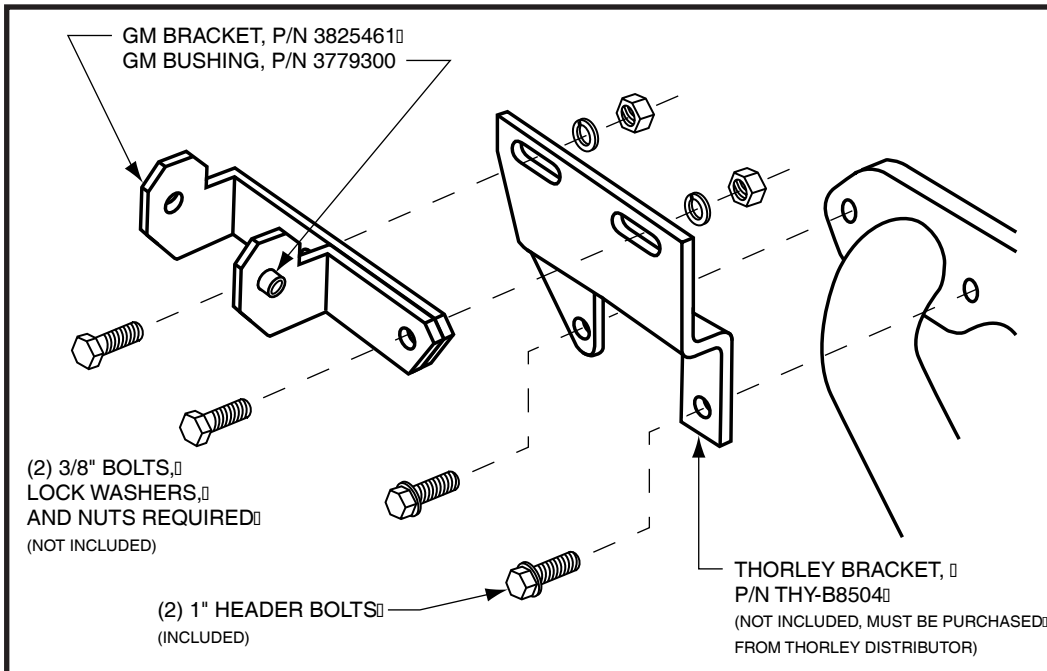
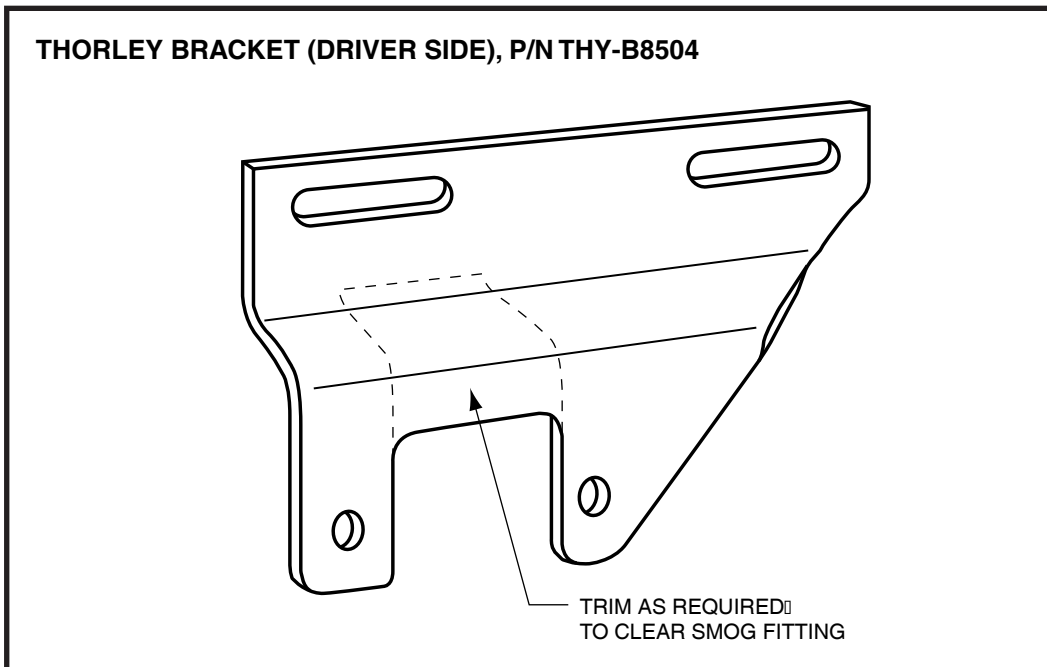

FIGURE 2



THY-372Y / THY-372Y-S

**CHEVROLET 283-400
67-72 PICKUP**

ILLUSTRATIONS

FIGURE 3

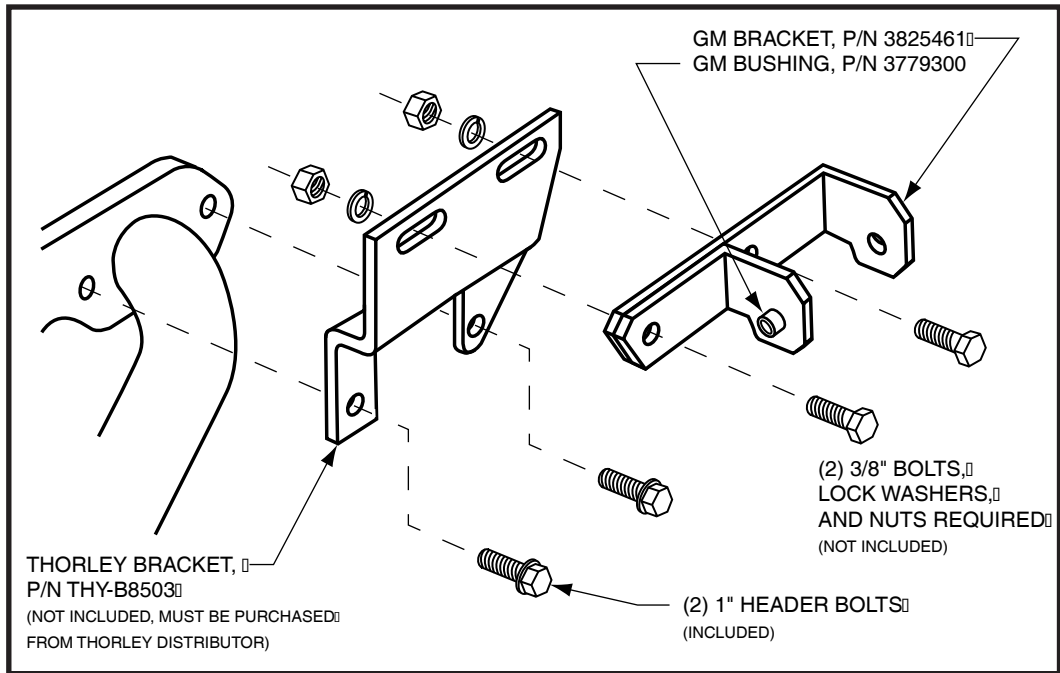
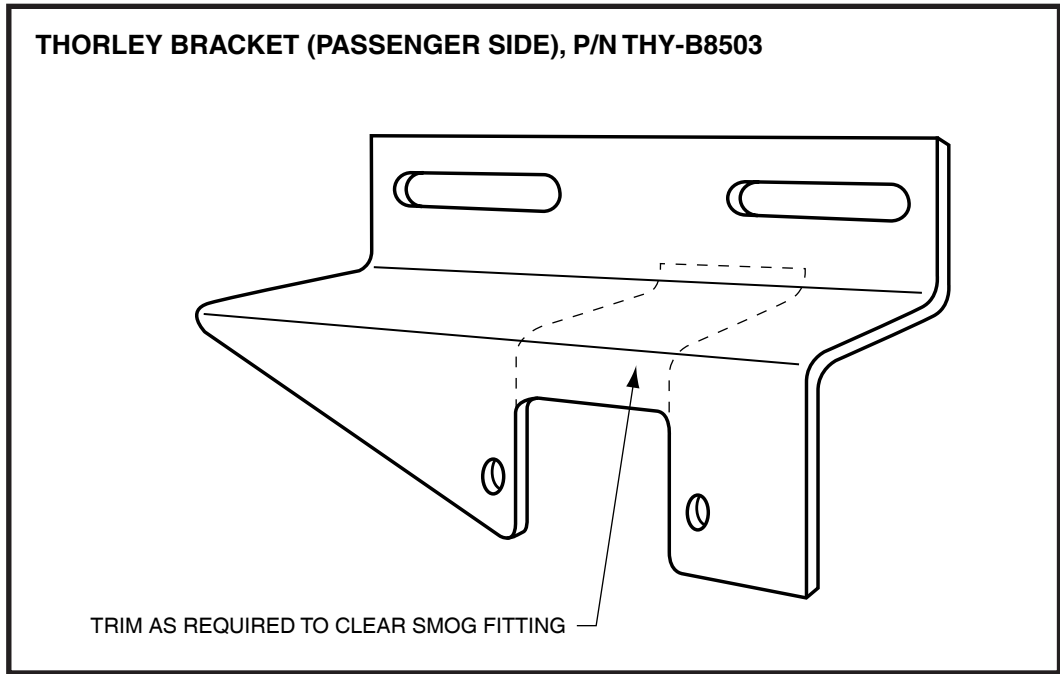

FIGURE 4



THY-372Y / THY-372Y-S

CHEVROLET 283-400
67-72 PICKUP

ILLUSTRATIONS

FIGURE 5

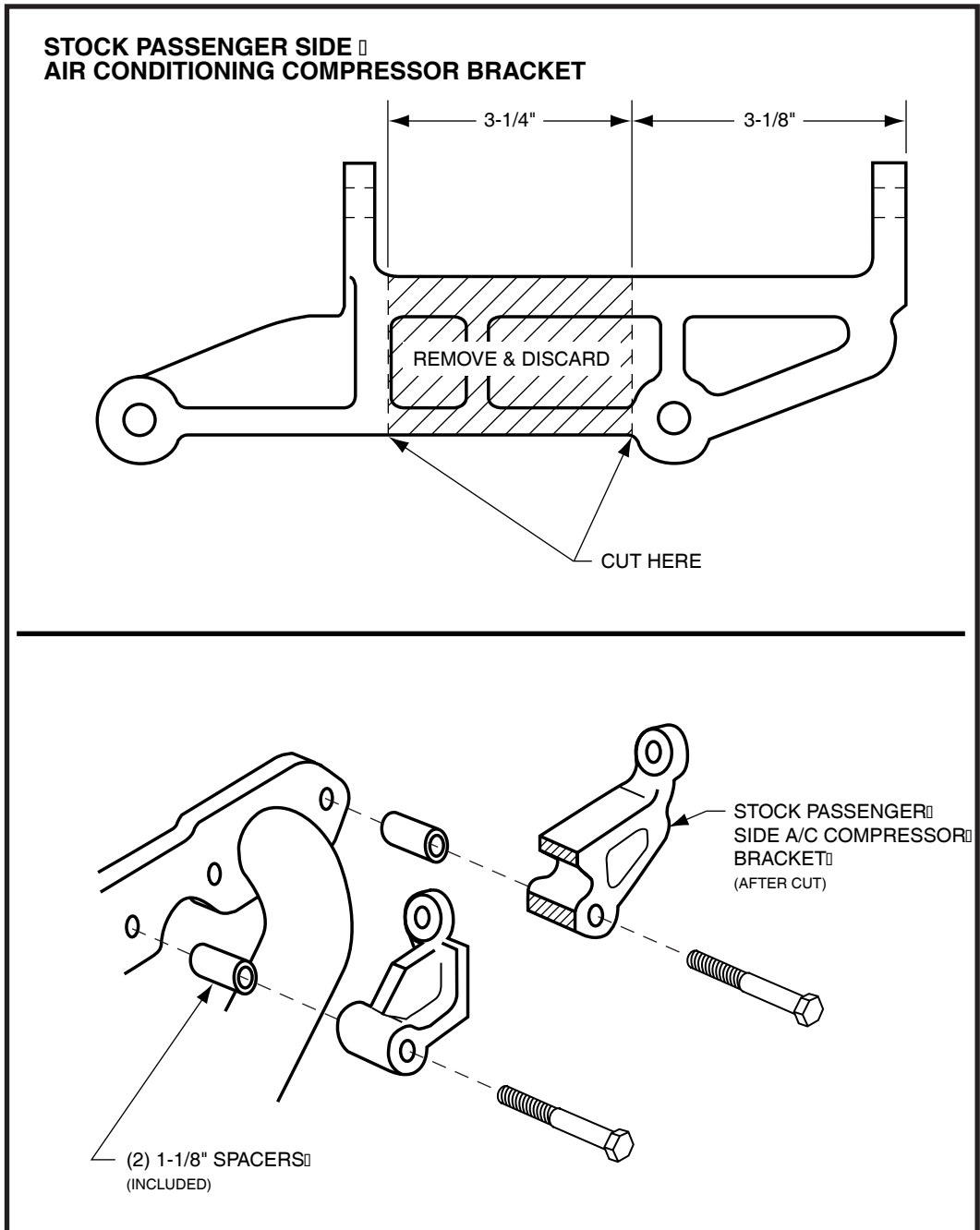

THY-372Y / THY-372Y-S

CHEVROLET 283-400
67-72 PICKUP

ILLUSTRATIONS

FIGURE 6

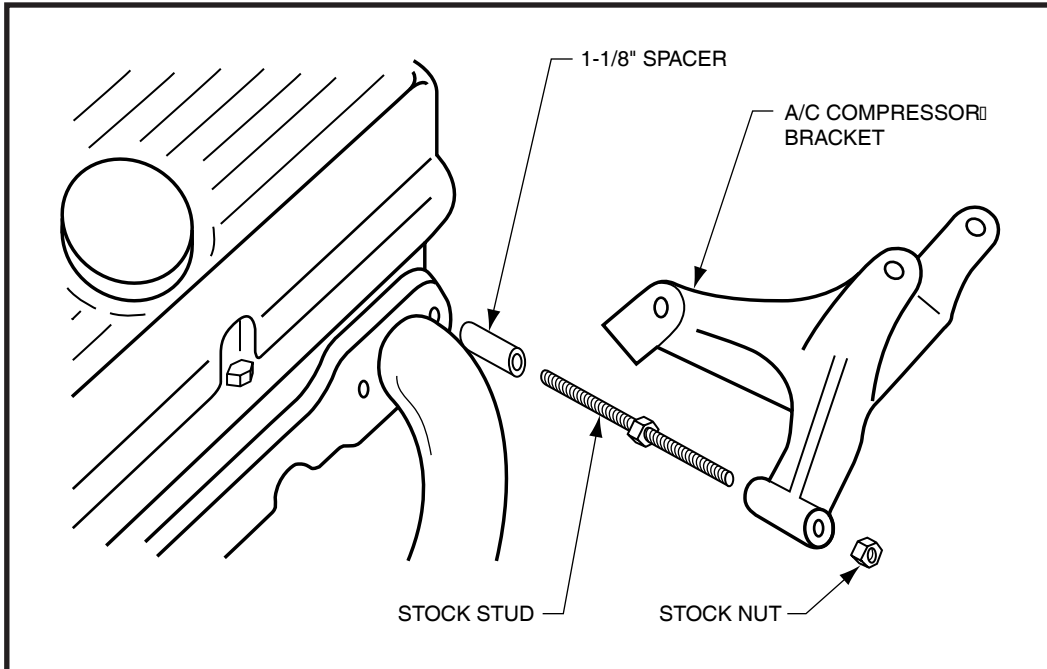
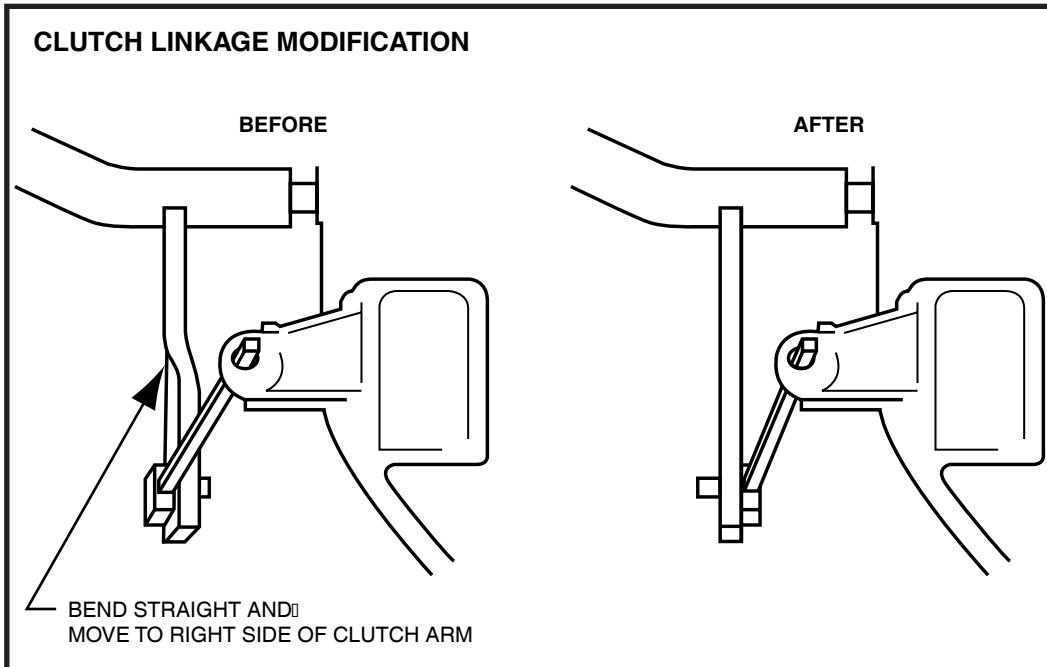

FIGURE 7



THY-372Y / THY-372Y-S

CHEVROLET 283-400
67-72 PICKUP

ILLUSTRATIONS

FIGURE 8

AIR CONDITIONING BRACKET MODIFICATION

